

# LIGHT



\_\_\_\_\_

\_\_\_\_\_

\_\_\_\_\_

--	--	--	--



# LIGHT



--	--	--	--

# LIGHT



	2					
Peak Wavelength	p	---	940	---	nm	I
		---	50	---	nm	I

2

--	--	--	--

Fig.1 Spectral Distribution

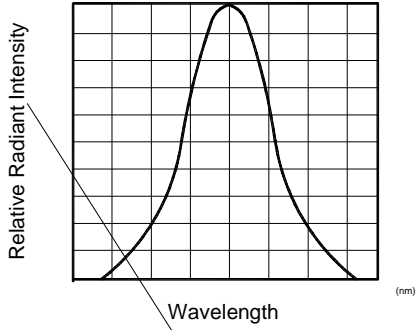

Fig.2 Forward Current Vs Ambient Temperature

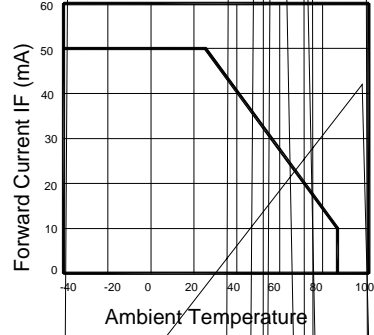

Fig.4 Relative Radiant Intensity Vs Ambient Temperature

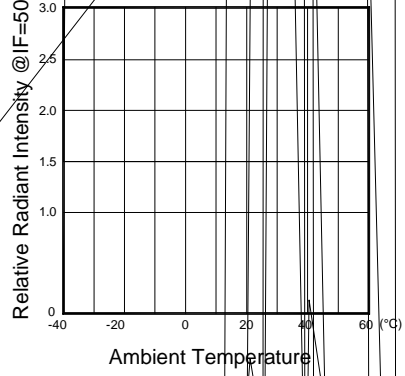
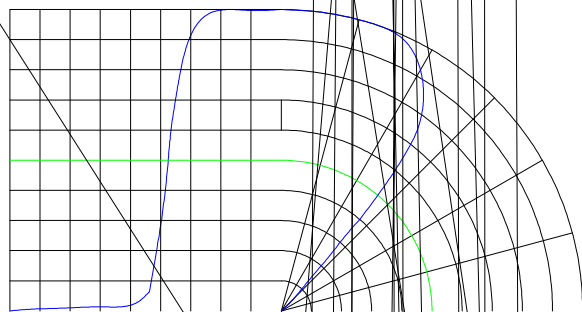
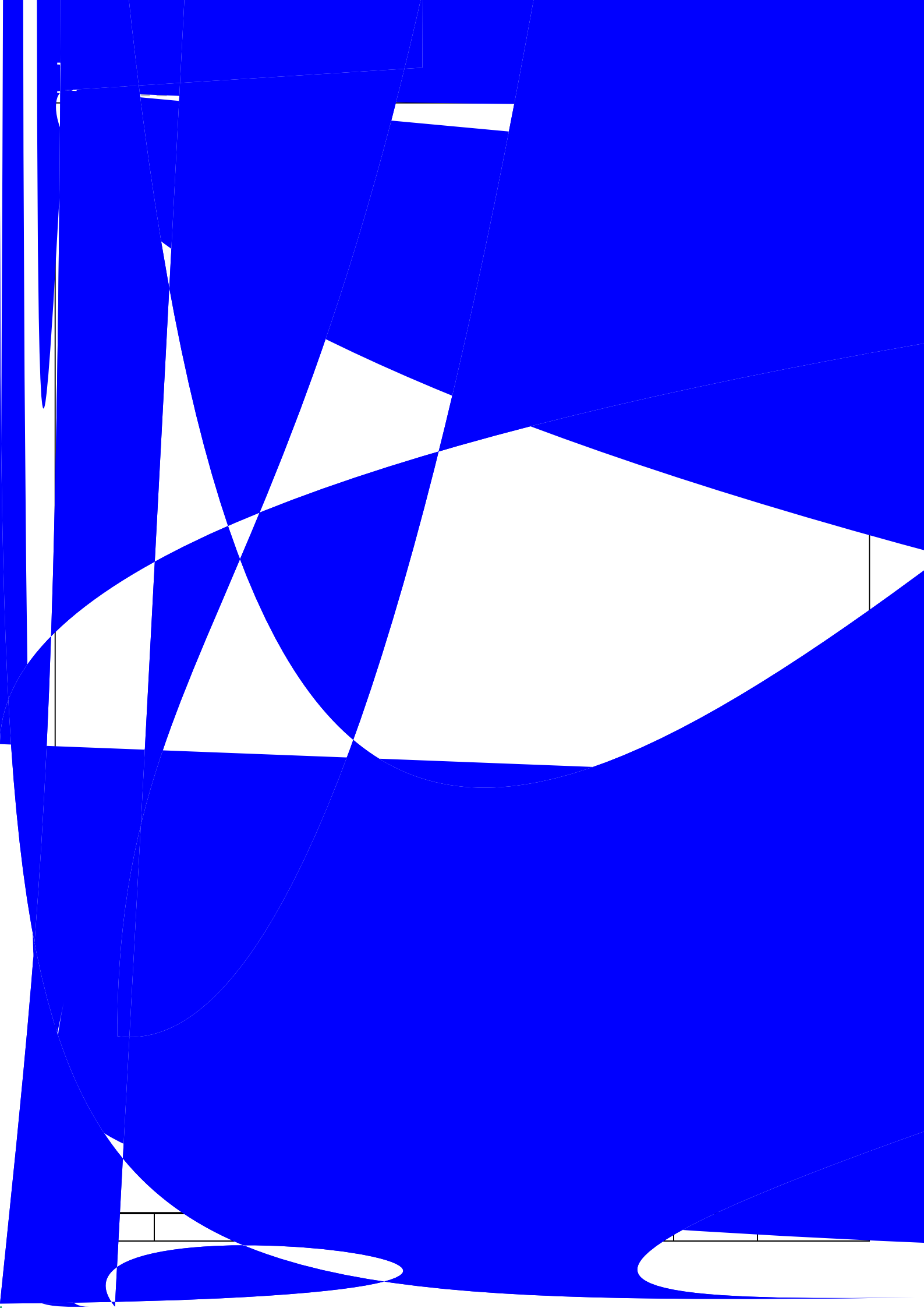

Fig.6 Radiation Diagram





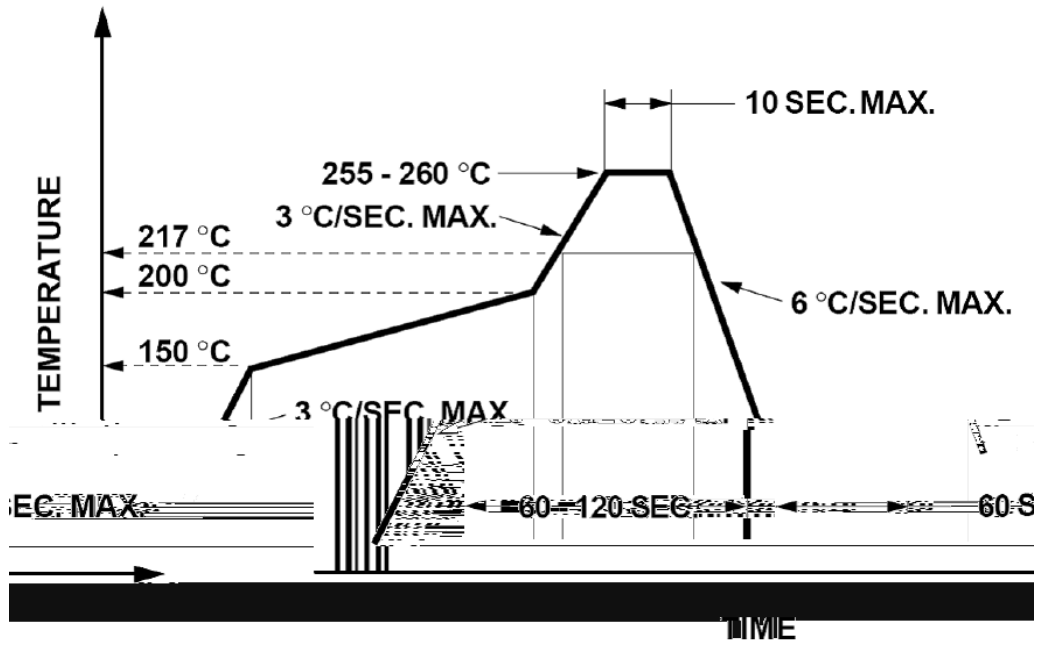

LIG

°C

