

Absolute Maximum Ratings at Ta=25

| Parameter | MAX. | Unit |
|---|-------------------------|------|
| Power Dissipation | 180 | mW |
| Continuous Forward Current | 100 | mA |
| Peak Forward Current ^{*2} | 1000 | mA |
| Reverse Voltage | 5 | V |
| Electrostatic Discharge (HBM) ^{*3} | 2000 | V |
| Moisture Sensitivity Level ^{*1} | 5a | |
| Operating Temperature | -40 to + 85 | |
| Storage Temperature | -40 to + 100 | |
| IR Reflow Temperature | 260 for 10 Seconds MAX. | |

1. Storage and operating:

- (1). Storage requirements before vacuum bag opened: Temperature<30

LIGHT

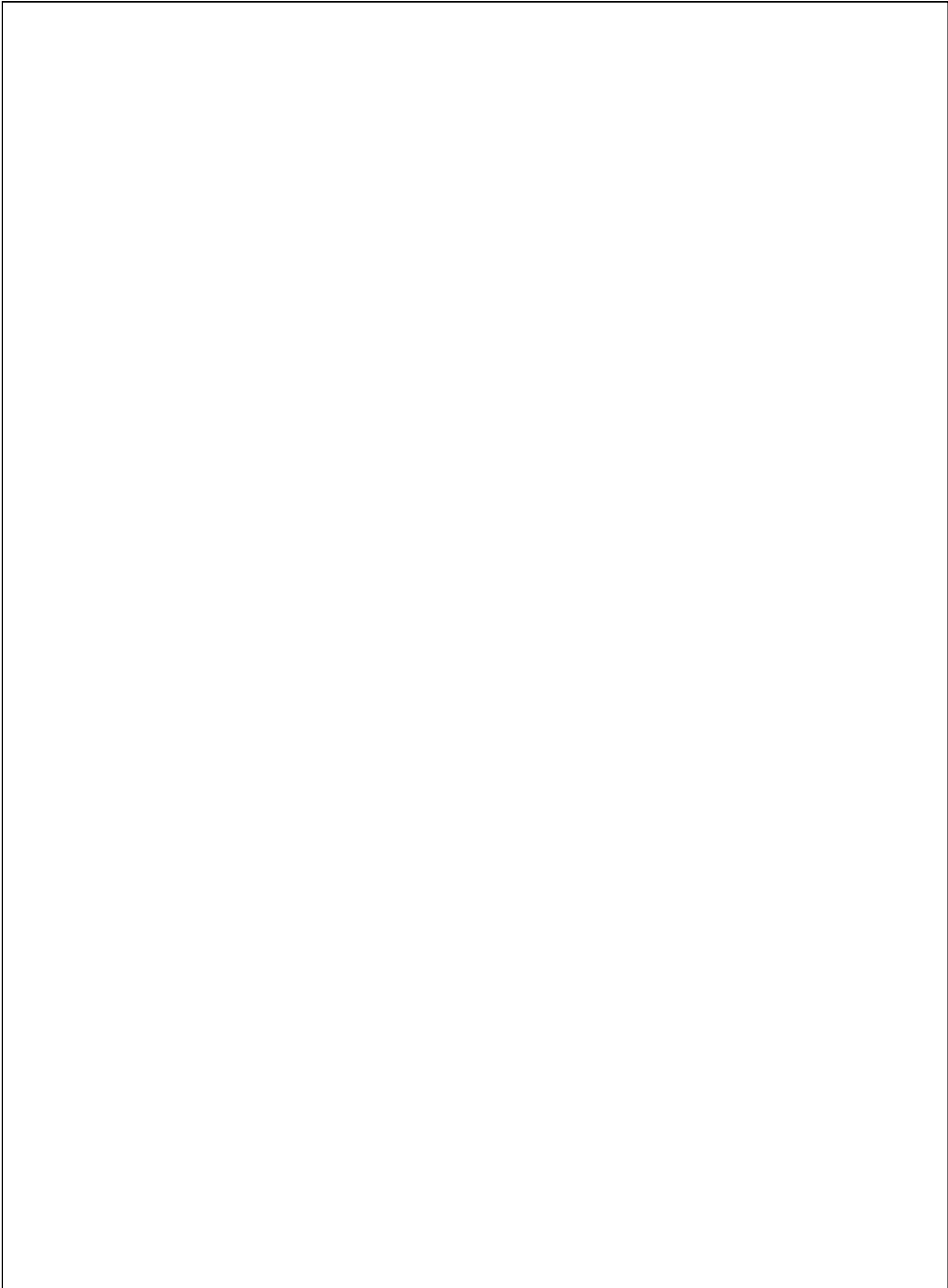

Typical Electrical / Optical Characteristics Curves (25 Ambient Temperature Unless Otherwise Noted)

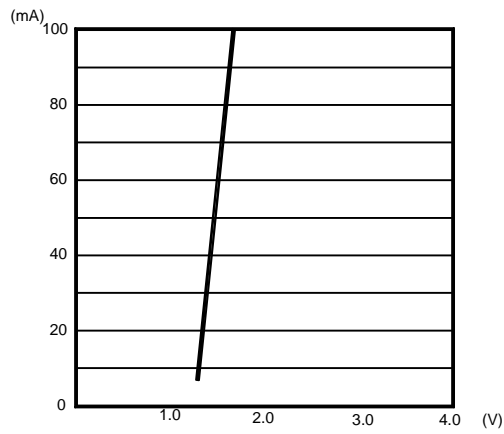
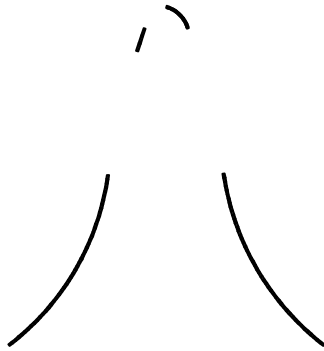

0.5 —————

Radiant Intensity Bin Code ($I_F=20\text{mA}$)

| BIN CODE | Min.(mW/sr) | Max. (mW/sr) |
|----------|-------------|--------------|
| 0 | 1.7 | 1.8 |
| 1 | 1.8 | 2.0 |
| 2 | 2.0 | 2.3 |
| 3 | 2.3 | 2.8 |

NOTE: The I_e guarantee should be added $\pm 15\%$ tolerance.

Carrier Tape Specifications (Loaded Quantity: 2000pcs/reel)

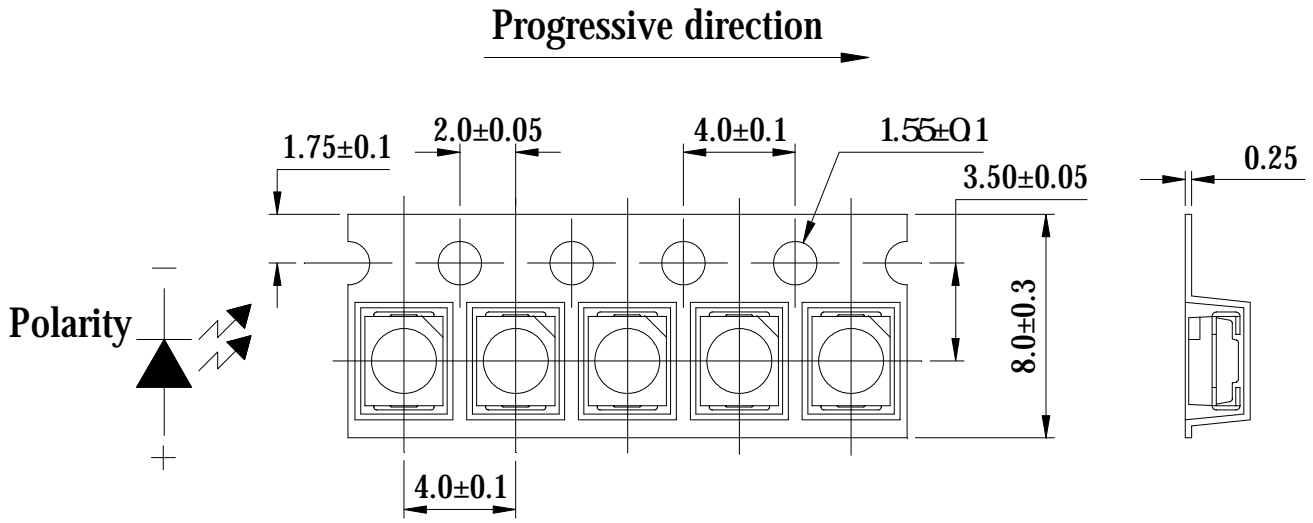

Note: Tolerance unless mentioned is ± 0.1 mm; Unit = mm

Moisture Resistant Packaging

Suggest IR Reflow Condition For Lead Free

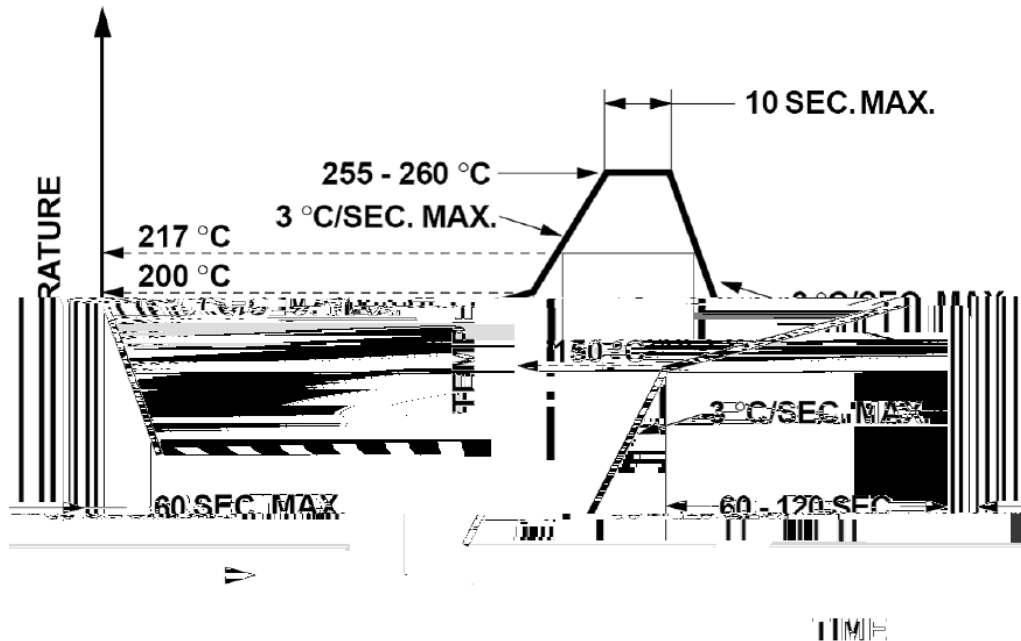

1. Reflow soldering should not be done more than two times.
2. When soldering, do not put stress on the LEDs during heating.

Soldering iron

1. When hand soldering, the temperature of the iron must less than 300 for 3 seconds.
2. The hand solder should be done only once.

Repairing

Repair should not be done after the LEDs have been soldered. When repairing is unavoidable, a double-head soldering iron should be used (as below figure). It should be confirmed beforehand whether the characteristics of LEDs will or will not be damaged by repairing.

