

SL-T3510RGBA-L120

DATA SHEET

SPEC.NO.: SZ18040901
DATE: 2018/04/09
REV. A/0

Approved By:

Checked By:

Prepared By:

SL-T3510RGBA-L120**TOP Full-color LED****Technical Data Sheet**

These products are full-color SMD component and designed for outdoor display with white refractor, high brightness,



Typical Characteristics Curves

Volt-Ampere Characteristics

Forward Current I_f (mA)

Relative Luminous Intensity VS Forward Current

Relative Luminous Intensity I_i (%)

Forward Current I_f (mA)

Forward Current Derating Curve

Forward Current I_f (mA)

Ambient Temperature T_a (°C)

Relative Spectral Distribution

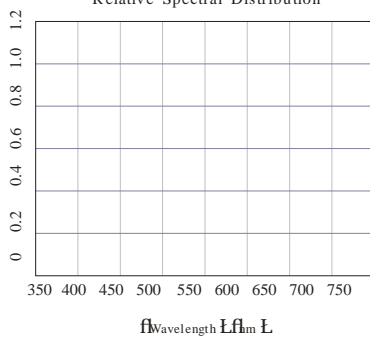

Reliability Test Items And Conditions

Test Items	Reference	Test Conditions	Time	Quantit	Crite
Thermal Shock	MIL-STD-202G	-40 (30min)←→100 (30min)	300 300 cycles	22	0/22
Temperature And Humidity Cyclic	JEITA ED-4701 200 203	-10 ———+65 0%-90%RH 24hrs./1cycle	10 10 cycles	22	0/22
High Temperature Storage	JEITA ED-4701 200 201	Ta=100	1000h	22	0/22
Low Temperature Storage	JEITA ED-4701 200 202	Ta=-40	1000h	22	0/22
High Temperature High Humidity Storage	JEITA ED-4701 100 103	Ta=60 RH=90%	1000h	22	0/22
Life Test	JESD22-A108D	Ta=25 IF _R =15mA,IF _G =8mA,IF _B =5mA	1000h	22	0/22
High Temperature Life Test	JESD22-A108D	Ta=85 IF _R =15mA,IF _G =8mA,IF _B =5mA	1000h	22	0/22
Low Temperature Life Test	JESD22-A108D	Ta=-40 IF _R =15mA,IF _G =8mA,IF _B =5mA	1000h	22	0/22
Resistance to Soldering Heat	GB/T 4937, .2.2&2.3	Tsol*=260 10sec.	2 2 times	22	0/22

Criteria For Judging Damage

Test Items	Symbol	Test Conditions	Criteria For Judging Damage
			295.61/T 4937.7200016 Tm 35.405

1

Packaging (1)

Carrier Tape

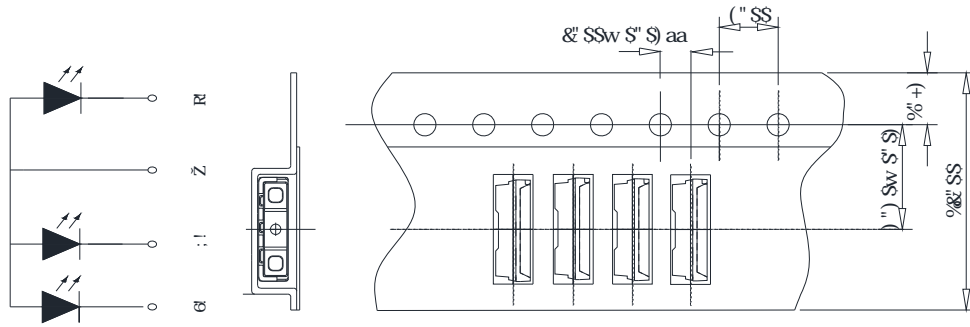

mm w0.10mm

All dimensions in mm, tolerances unless mentioned is w0.10 mm.

Details Of Carrier Tape

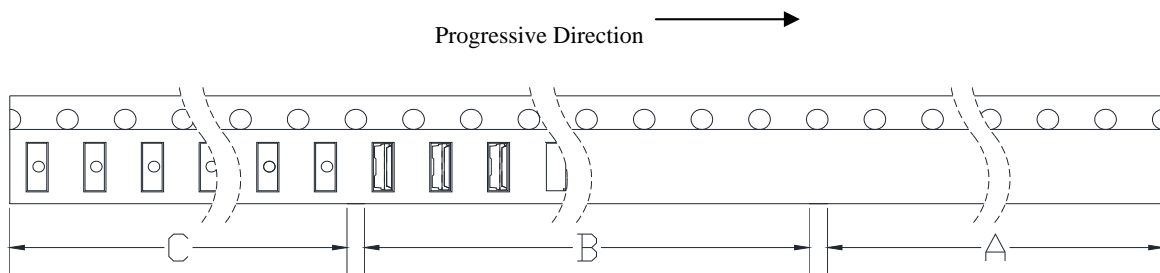

Reel Dimension

Label

2

Packaging(2)

✧ **Moisture Proof and Anti-Electrostatic Foil Bag**

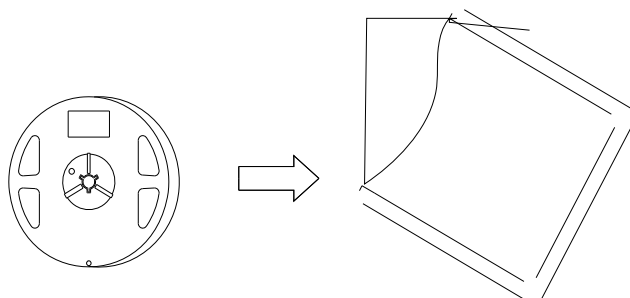

✧ **Cardboard Box**

✧ **Label Explanation**

TYPE	
QTY	Quantity
BIN	Rank
SC:	Bin Code
LOT	Lot Number
λd	Wavelength Range
IV	Luminous Intensity Range
VF	Forward Voltage Range
IF	Test Current

LIGHT



2



Guideline for Soldering (2)

-
- Reflow soldering should not be done more than one time.
- LED
- Stress on the LEDs should be avoided during heating in the reflow soldering process.
-
- After soldering, do not deal with the product before its temperature drop down to room temperature.

3.

Cleaning

- 30 30 3 50 LED

It is recommended that alcohol Anhydrous ethanol be used as a solvent for cleaning after soldering. Cleaning is to go under 30 for 3 minutes or 50 for 30 seconds. When using other solvents, it should be confirmed beforehand whether the solvents will dissolve the package and the resin or not.

- 300W LED

Ultrasonic cleaning is also an effective way for cleaning. The influence of Ultrasonic cleaning on LED depends on factors such as ultrasonic power. Generally, the ultrasonic power should not be higher than 300W, otherwise it will cause LED damage. Before cleaning, a pre-test should be done to confirm if any damage to LEDs will occur.

PCB

P76

hY T\]g [YbYfU [i]XY]bYaUmbch Udd` mhc U` P76 XYg] [bg UbXWbZ] [i fUh] cbg cZU` gc` Xf] b[Yei] daYbh" T\YhYWb] ei Y]b dfUW] W]g]bZ i YbWX VmaUmZUMcf gž]h g`ci` X WY gdYV]U]nYX VUgY cb h\Y P76 XYg] [bg UbXWbZ] [i fUh] cbg cZ h\Y gc` Xf] b[Yei] daYbh"

(2)

Precautions (2)

3.

Design Consideration

- LED

In designing a circuit, the current through each LED must not exceed the absolute maximum rating specified for each LED. In the meanwhile, resistors for protection should be applied, otherwise slight voltage shift will cause big current change which will probably lead to damage.

- | | | |
|-----|-------|-----|
| A | LED | B |
| LED | V_F | LED |

It is recommended to use Circuit A which regulates the current flowing through each LED rather than Circuit B. When driving LEDs with a constant voltage in Circuit B, the current through the LEDs may vary due to the variation in Forward Voltage (V_F) of the LEDs. In the worst case, some LED may be subjected to stress in the excess of the Absolute Maximum Rating.

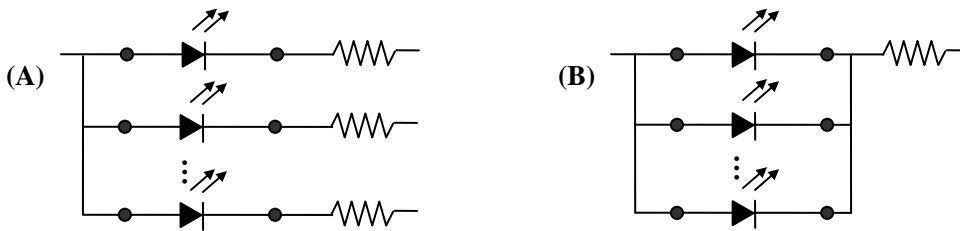

- LED

Thermal Design is paramount importance because heat generation may result in the Characteristics decline, such as brightness decrease, Color change and so on. Please consider the heat dissipation when making the system design.

4.

Reverse voltage protection

- | | |
|-----|-----|
| LED | LED |
| LED | |
| LED | 5V |

In general, the reverse current of LED is very small, which won't affect the normal use of components. But when it is often suffered the reverse voltage which exceeds the limit of the component then it will be damaged.

(3)

Precautions (3)

Such as the reverse current increase rapidly. And it will cause the string light when the screen is black. So please pay attention to controlling the reverse voltage which less than 5V is recommended.

5.

The safe temperature for LEDs working

- LED

55

75

The high temperature will make the LEDs' Luminous Intensity decreased radically, if LEDs are used in hot environment for a long time, they will be disabled easily. When LEDs are used in a high density array, we suggest that the LEDs' surface temperature should be lower than 55 and the legs' temperature should be lower than 75 .

6.

Others

-

When handling the product, touching the encapsulation with bare hands will not only contaminate its surface, but also have an effect on its optical characteristics. Excessive force to the encapsulation might result in catastrophic failure of the LEDs due to die breakage or wire deformation. For this reason, please do not put excessive stress on LEDs, especially when the LEDs are heated such as during Reflow Soldering.

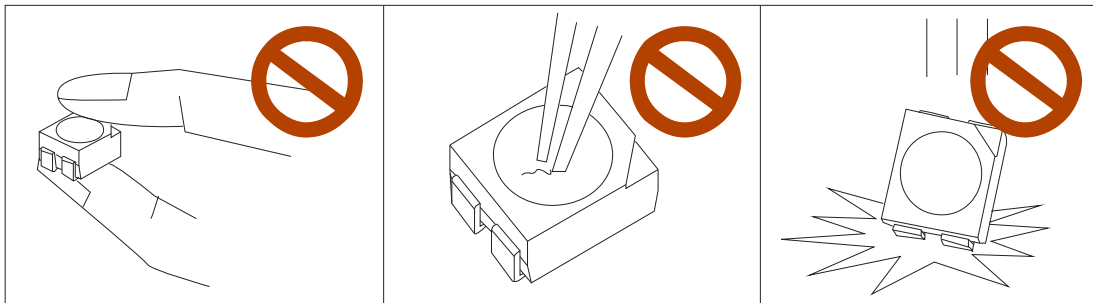

- LED

The epoxy resin of encapsulation is fragile, so please avoid scratch or friction over the epoxy resin surface.

While handling the product with tweezers, do not hold by the epoxy resin, be careful.